

(autotronic₈₃₄

(autotronic₈₃₆

Installation, operation and maintenance instructions



Please note the additional information:

Installation instructions for panic and emergency exit door locks 834P/836P



Declaration of performance 834/834P/836/836P



Inhalt

1	Introduction.....	3
2	Wichtige Informationen / Sicherheitshinweise.....	4
2.1	BasiC Components.....	5
2.2	certifications labelling of the locks.....	6
3	Installation examples.....	8
3.1	Version 1 – Standard – with cable junction/without control unit.....	8
3.2	Version 2 – Standard – with tappet contact/without control unit.....	10
3.3	Version 3 – Standard – with tappet contact and switching power supply unit on the frame/without control unit..	12
3.4	Version 4 – Standard – All-inclusive for installation in the door.....	14
3.5	Version 5 – Project – All-inclusive with DIN rail components.....	16
3.6	Version 6 – Project – All-inclusive with control box.....	18
4	Installation instructions.....	20
4.1	Routing and drilling operations.....	20
4.2	installation.....	25
5	Commissioning.....	32
5.1	Operation verification check on the fabricator’s premises.....	32
5.2	Commissioning on site.....	32
5.3	Settting possibilities.....	33
6	External connection options.....	34
6.1	The radio receiver module.....	35
6.2	The Control unit.....	36
6.3	The drive unit’s multi-functional jack.....	40
7	Wiring diagram.....	41
8	Control via FUHR radio access control systems.....	42
8.1	The programming keys.....	42
8.2	Tuning in and deleting user radio keys.....	43
9	Maintenance and care.....	46
9.1	Contact device.....	47
9.2	Battery change of the radio keys.....	48
10	Technical data.....	49
10.1	Master-/user radio key.....	49
10.2	radio key with wall bracket.....	49
10.3	FUHR autotronic control with radio receiver.....	50
10.4	radio receiver.....	50
10.5	FUHR autotronic Motor drive unit.....	50
10.6	FUHR autotronic switching power supply unit (installation in the door frame).....	51
11	Troubleshooting.....	52
11.1	use with control unit.....	52
11.2	use with radio receiver module.....	53
12	Optional accessories.....	54



Important advices which have to be noticed



www.fuhr.de

For this manual in other languages see www.fuhr.de

1 Introduction

The FUHR **autotronic** 834 and 836 multipoint locking systems lock doors automatically by means of magnetic triggering upon closing over the door. The convenient unlocking is motorised via two high-performance motors working in parallel - reliable, strong and fast. There is a choice of different opening variants:

- Via the intercom system
- Via FUHR access control systems such as radio keys, radio fingerprint scanner, radio transponders, radio keypads, Smart-Touch or SmartConnect easy/door
- Via external access control systems of all types.

Advantages of automatic locking:

- Saves energy because the door always closes tight.
- House, flat, object or side entrance doors are always securely closed.
- Suitable for all door materials.

A mechanical opening with the key of the standard profile cylinder (no freewheel cylinder required) is also possible at any time, e.g. in case of power failure. The door can be opened from the inside simply by using the lever handle.

The standard locking and unlocking functions in detail:

Special functions are described in chapter 6.

Locking (closing):

When the door is closed, the sturdy latching deadbolts or the latching and hook bolt combinations automatically extend to 20 mm and are protected against being pushed back.

By triggering the central deadbolt via the cylinder, the entire locking system is mechanically secured. All possibilities of opening by means of the drive unit are deactivated. At the same time the internal lever handle is blocked for control purposes or as a child safety lock.

Unlocking (opening) from the outside:

- With the key of the profile cylinder
- Optionally via a FUHR radio access control system, such as radio key, radio fingerprint scanner, etc., or alternatively via any other access control system

Unlocking (opening) from the inside:

- As usual via the door handle or the key of the profile cylinder
- Optionally via a house intercom system (6-12 V AC, 6-24 V DC or potential-free)
- Optionally via a FUHR radio access control system, e.g. radio key
- Optionally via another access control system (release signal via potential-free contact)
- Optionally via a building management system

Further electrical connections are available for: (some are only operated by control)

- Alarm systems
- Access control systems
- Electrically operated door openers
- External control LED
- Time switches (permanent-open function or day latch function, via cable or radio activation)
- Electronical shutdown signal of the access control systems for alarm systems

2 Wichtige Informationen/Sicherheitshinweise

These instructions are aimed at door fabricators and contain important information regarding installation, commissioning and operation pertaining to the FUHR **autotronic 834** and **autotronic 836** multipoint locking systems. Please read carefully **prior** to installation and commissioning. The points raised here provide supplementary information to the FUHR Product Liability Information for door locks, see www.fuhr.de. In the event of non-compliance with these imperative instructions, faultless system operation cannot be warranted. We assume that the installation as well as commissioning and maintenance is carried out exclusively by professional staff.

The FUHR **autotronic 834** and **autotronic 836** multipoint locking systems has been designed and manufactured taking safety-related regulations and harmonised standards into account. This product's safety features are an essential pre-requisite for the EN 14846 accreditation. Therefore no alterations or modifications may be carried out other than those described in these instructions.



The safety of the FUHR autotronic 834/836 product largely depends on its correct installation and regular maintenance! The installation of the electronic components requires particular care, since abrasion points, defective cables, damaged contacts, etc. affect security and can lead to the malfunction of the system. Please ensure that all components are in perfect functioning condition prior to installation. Damaged or defective components may not be used under any circumstances. Use the locking system only in technically perfect condition! Malfunctions that impair security are to be eliminated immediately. Until the malfunction has been eliminated, the drive unit is to be switched off and operated mechanically! The power supply unit's power feed is to be disconnected when working on the locking system and live components.

The FUHR **autotronic 834** and **autotronic 836** multi point locking systems are designed for use with the FUHR **autotronic** components. No liability is accepted if the system is installed incorrectly and/or if non-original or non-factory-approved system accessories are used. The modification of components or the use of non-approved accessories can cause malfunctions. In the event of damage to property or personal injury resulting from non-observance of the installation and operating and maintenance instructions or improper handling, the warranty shall become null and void. We do not accept any guarantee for consequential damage resulting from this.



The FUHR autotronic 834 and 836 multipoint locking systems must be protected from humidity. They are not suitable for areas with high humidity and chemical substances. All possible water ingress points must be sealed.

The FUHR **autotronic 834** and **autotronic 836** multipoint locking systems have been primarily designed for installation in main entrance doors, apartment doors and back doors. Products manufactured in accordance with EN 14846 requirements provide a high level of personal protection and adequate protection against intrusion when fitted to a suitable door and door frame. The system with 2 latching deadbolts (type 4) or automatic latching and hook bolts (type 10) is regularly subjected to both internal and external tests. For this purpose durability testing in the highest grade (class 7) with 200,000 operations was carried out successfully.

The installation steps depicted on the following pages serve as a schematic diagram. Due to the numerous profiles available on the market, there may be slight deviations in specific points. Please feel free to request a profile-related routing drawing! Please contact your sales partner or the manufacturer in the event of discrepancies or queries.

The indicated sequence in these installation instructions is exemplary. The sequence may be varied if required..



IMPORTANT!

To ensure access at all times even in emergencies (e.g. power failure), a key to the cylinder should always be carried.

2.1 BASIC COMPONENTS

FUHR autotronic 834 or autotronic 836 multipoint locking system with one-piece or standard strike plates

The scope of delivery depends on the respective design variant.
The basic components are shown below.





2.2 CERTIFICATIONS | LABELLING OF THE LOCKS

The following must be observed for VdS approved locking systems:

A VdS approved profile cylinder must be installed in the VdS approved multipoint locking system. The profile cylinder shall be protected with a VdS approved or DIN tested burglar-resistant door plate.

The key shall always be kept in a safe place so that it is only accessible to the authorised person. If a key is lost, the cylinder must be replaced immediately or converted to a new lock by changing the coding or the coding of the lost key must be blocked/deleted. The required class for these components depends on the class of the lock and can be taken from the following table:

autotronic 834 – VdS approval class A

Lock	Profile cylinder	VdS approved door plate	DIN tested to DIN 18 257
Class A	Class A	at least Class AZ	at least Class ES 1-ZA
	Class AZ	at least Class A	at least Class ES 1

autotronic 836 – VdS-Anerkennung Klasse C

Lock	Profile cylinder	VdS approved door plate	DIN tested to DIN 18 257
Class C	Class C	at least Class CZ	at least Class ES 3-ZA
	Class CZ	at least Class C	at least Class ES 3

Further certifications/tests:



Certified according to DIN 18251-3



Tested according to EN 14846



Certified according to QM342



Certified according to BRL 3104 / NEN 5089: 2009, Class 2



Certified according to BRL 3104 / NEN 5089: 2009, Class 3



Certified according to EN 179 / 1125

3 Installation examples

3.1 VERSION 1 – STANDARD – WITH CABLE JUNCTION/WITHOUT CONTROL UNIT

Functions:

- Opening impulse via a two-way intercom system
- Connects up to external indicator LED Art. no. VNZ80067

System components:

Multipoint locking system
FUHR autotronic 834
or autotronic 836
 incl. electromotive
 drive unit



Profile related one-piece system strike plate
 + to be ordered separately:
contact magnet for the motor drive
 (Art. no. VNZM14195)
and magnet release for type 4 resp. type 10
 (Art. no. depending on version)



Concealed or surface-mounted cable junction
 Art. no. VNZ80090/VNZ80089



DIN rail power supply unit
 Art. no. VNZT80345



Cable protection elements for secure cable laying:
Cover plate | 2 m | F16 – Art. no. VNZ33171X |
 F20 – Art. no. VNZ33172X | F24 – Art. no. VNZ33173X
Double cable guides for Euro-groove – Art. no. VNZ13845
End caps for cover plate | F16 – Art. no. VNZ13846 |
 F20 – Art. no. VNZ13847
Cable protection sleeves – Art. no. VNZ80022



6-core connection cable | 10 m | with one plug
 Art. no. VNZ80075



Principle of connection with type 4 (type 10 analogue)

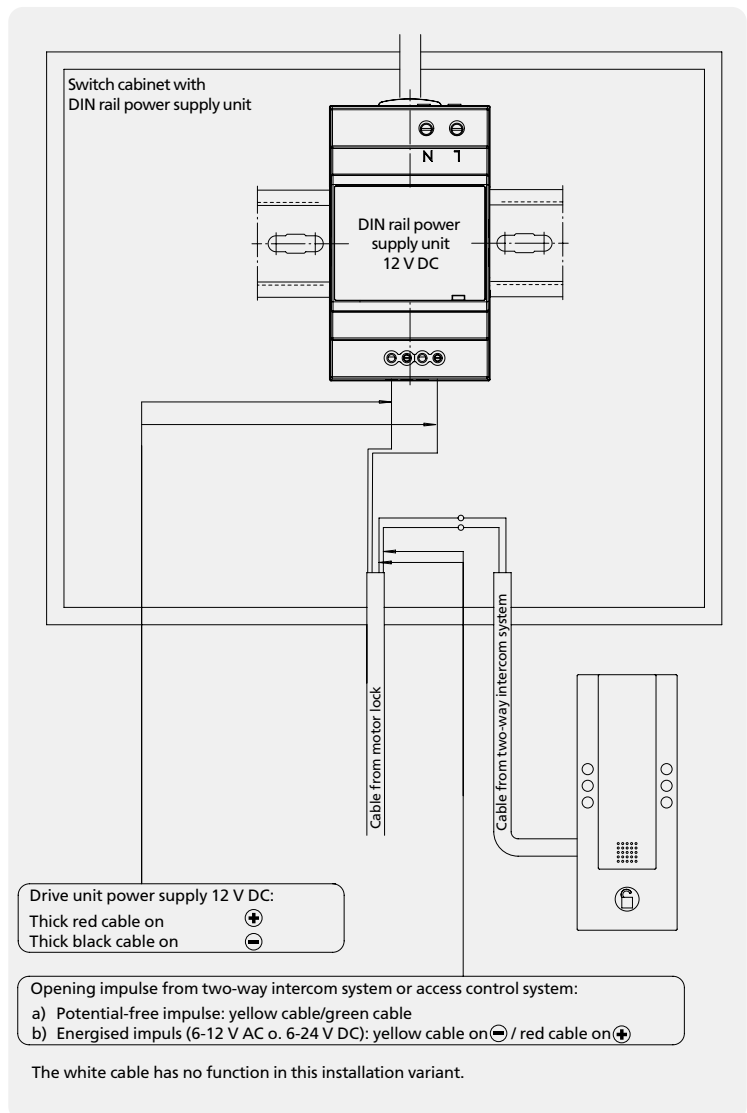

3.2 VERSION 2 – STANDARD – WITH TAPPET CONTACT /WITHOUT CONTROL UNIT

Functions:

- Opening impulse via a two-way intercom system
- Connects up to external indicator LED Art. no. VNZ80067

System components:

Multipoint locking system
FUHR autotronic 834
or autotronic 836
 incl. electromotive
 drive unit



Profile related one-piece system strike plate + to be ordered separately:
contact magnet for the motor drive
 (Art. no. VNZM14195)
and magnet release for type 4 resp. type 10
 (Art. no. depending on version)



Profile related tappet contacts

Cable connector (length 4000 mm) with preassembled multi-functional jack

Contact surface

Cable connector (length 250 mm) preassembled



DIN rail power supply unit

Art. no. VNZT80345



Cable protection elements for secure cable laying:

Cover plate | 2 m | F16 – Art. no. VNZ33171X |
 F20 – Art. no. VNZ33172X | F24 – Art. no. VNZ33173X

Double cable guides for Euro-groove – Art. no. VNZ13845

End caps for cover plate | F16 – Art. no. VNZ13846 |
 F20 – Art. no. VNZ13847

Cable protection sleeves – Art. no.. VNZ80022



3-core connection cable | 8 m | with one coupler

Art. no. VNZ80063A



Principle of connection with type 4 (type 10 analogue)

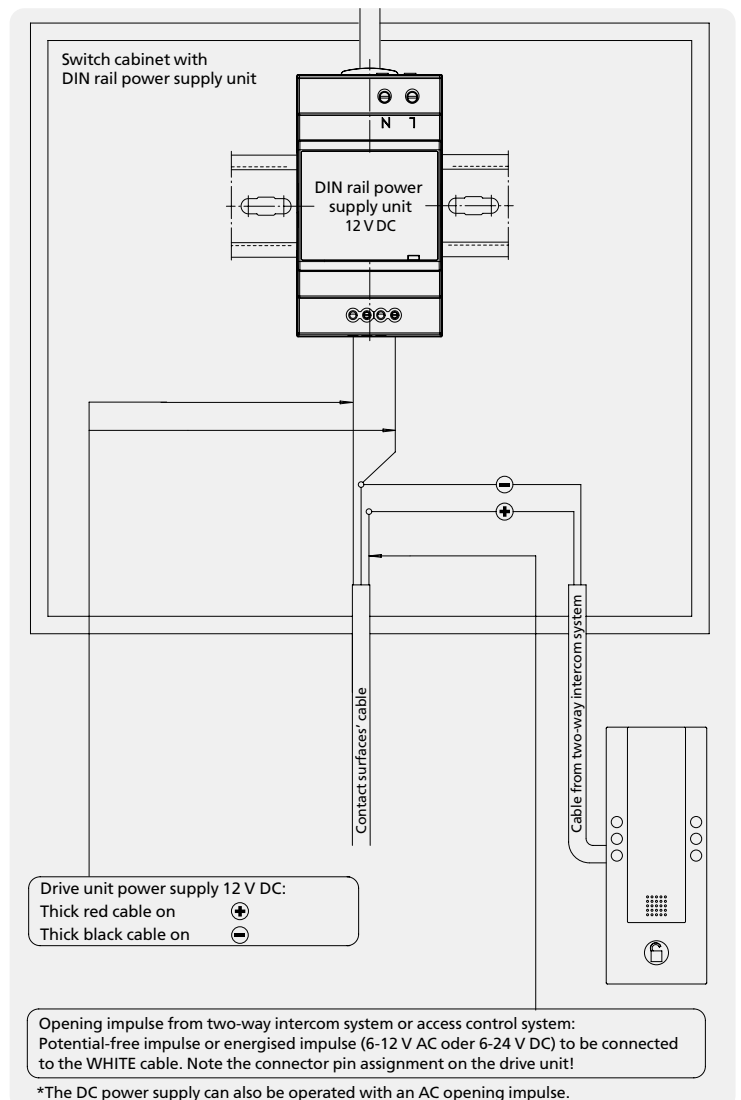

PLEASE NOTE – connector pin assignment on the drive unit:

If the tappet contacts are used **without** the control unit, the **white** cable from the green drive unit's coupler for the door opening impulse must be shifted from terminal 1 to:

- in case of potential-free impulse: to terminal 4
- in case of an electrical impulse: to terminal 7

3.3 VERSION 3 – STANDARD – WITH TAPPET CONTACT AND SWITCHING POWER SUPPLY UNIT ON THE FRAME/WITHOUT CONTROL UNIT

Functions:

- Opening impulse via a two-way intercom system
- Connects up to external indicator LED Art. no. VNZ80067

System components:

Multipoint locking system FUHR autotronic 834 or autotronic 836
incl. electromotive drive unit



Profile related one-piece system strike plate + to be ordered separately: contact magnet for the motor drive
(Art. no. VNZM14195) **and magnet release for type 4 resp. type 10**
(Art. no. depending on version)



Profile related tappet contacts

Cable connector (length 4000 mm) with preassembled multi-functional jack

Contact surface

Cable connector (length 250 mm) preassembled



Profile related switching power supply unit

For installation in the door frame
230 V AC input/12 V DC output,
Cable connectors 230 V (length 3,000 mm - surface-mounted cable), Earth cable (length 400 mm) and 12 V (length 200 mm)
Preassembled



Cable protection elements for secure cable laying:

Cover plate | 2 m | F16 – Art. no. VNZ33171X |

F20 – Art. no. VNZ33172X | F24 – Art. no. VNZ33173X

Double cable guides for Euro-groove – Art. no. VNZ13845

End caps for cover plate | F16 – Art. no. VNZ13846 |

F20 – Art. no. VNZ13847

Cable protection sleeves – Art. no.. VNZ80022



4-core connection cable | 1 m | with two couplers

Art. no. VNZ80118B



Principle of connection with type 4 (type 10 analogue)



PLEASE NOTE – connector pin assignment on the drive unit:

If the tappet contacts are used **without** the control unit, the **white** cable from the green drive unit's coupler for the door opening impulse must be shifted from terminal 1 to:

- in case of potential-free impulse: to terminal 4
- in case of an electrical impulse: to terminal 7

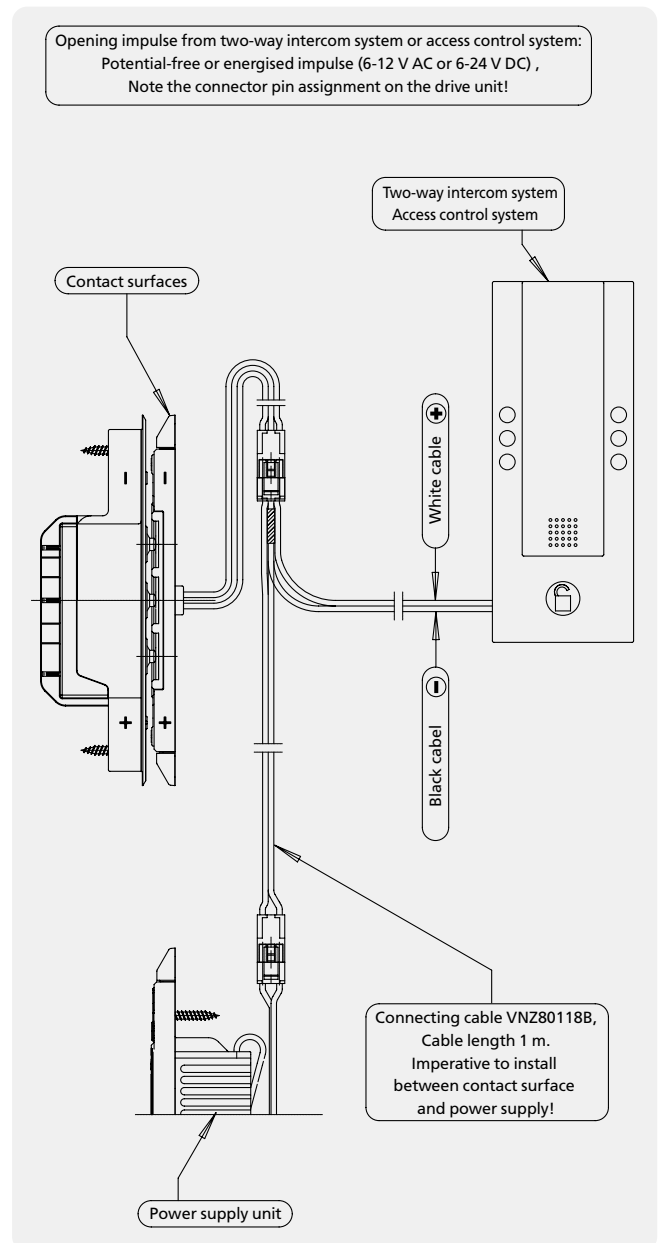

3.4 VERSION 4 – STANDARD – ALL-INCLUSIVE FOR INSTALLATION IN THE DOOR

Functions:

- Opens via FUHR radio-controlled access control modules such as radio key, fingerprint scanner or transponder
- Integration in facility management systems
- Connection to external access control systems
- Connects up to an alarm system
- Connects up to a swing door opener
- Connects up to time switches (permanently-open function)
- Connects up to external indicator LED Art. no. VNZ80067
- Input signal to electronically disconnect the access control systems for alarm systems

System components:

Multipoint locking system
FUHR autotronic 834
or autotronic 836
 incl. electromotive drive unit



Profile related one-piece system strike plate + to be ordered separately:
contact magnet for the motor drive
 (Art. no. VNZM14195)
and magnet release for type 4 resp. type 10
 (Art. no. depending on version)



Profile related tappet contacts

Cable connector (length 4000 mm) with preassembled multi-functional jack

Contact surface

Cable connector (length 250 mm) preassembled



Control unit with master radio key

For installation in the door frame
 Cable connectors (length 300 and 200 mm), preassembled
 Art. no. VNZASTP0019



Cable protection elements for secure cable laying:

Cover plate | 2 m | F16 – Art. no. VNZ33171X | F20 – Art. no. VNZ33172X | F24 – Art. no. VNZ33173X
Double cable guides for Euro-groove – Art. no. VNZ13845
End caps for cover plate | F16 – Art. no. VNZ13846 | F20 – Art. no. VNZ13847
Cable protection sleeves – Art. no. VNZ80022



Profile related switching power supply unit

For installation in the door frame
 230 V AC input/12 V DC output,
 Cable connectors 230 V (length 3,000 mm - surface-mounted cable), Earth cable (length 400 mm) and 12 V (length 200 mm)
 Preassembled



Principle of connection with type 4 (type 10 analogue)



The illustration shows the door from the inside.
Always mount the control unit on the inside.

3.5 VERSION 5 – PROJECT – ALL-INCLUSIVE WITH DIN RAIL COMPONENTS

Functions:

- Opens via FUHR radio-controlled access control modules such as radio key, fingerprint scanner or transponder
- Integration in facility management systems
- Connection to external access control systems
- Connects up to an alarm system
- Connects up to a swing door opener
- Connects up to time switches (permanently-open function)
- Connects up to external indicator LED Art. no. VNZ80067
- Input signal to electronically disconnect the access control systems for alarm systems

System components:

**Multipoint locking system
FUHR autotronic 834
or autotronic 836**
incl. electromotive
drive unit



**Profile related one-
piece system strike plate
+ to be ordered sepa-
rately:
contact magnet for the
motor drive**
(Art. no. VNZM14195)
**and magnet release
for type 4 resp. type 10**
(Art. no. depending on
version)



Profile related tappet contacts

Cable connector (length 4000 mm) with
preassembled multi-functional jack

Contact surface

Cable connector (length 250 mm)
preassembled



DIN rail control unit with master radio key

Art. no. VNZASTP80257



Cable protection elements for secure cable laying:

Cover plate | 2 m | F16 – Art. no. VNZ33171X |

F20 – Art. no. VNZ33172X | F24 – Art. no. VNZ33173X

Double cable guides for Euro-groove – Art. no. VNZ13845

End caps for cover plate | F16 – Art. no. VNZ13846 |

F20 – Art. no. VNZ13847

Cable protection sleeves – Art. no.. VNZ80022



DIN rail power supply unit

Art. no. VNZT80345



Principle of connection with type 4 (type 10 analogue)

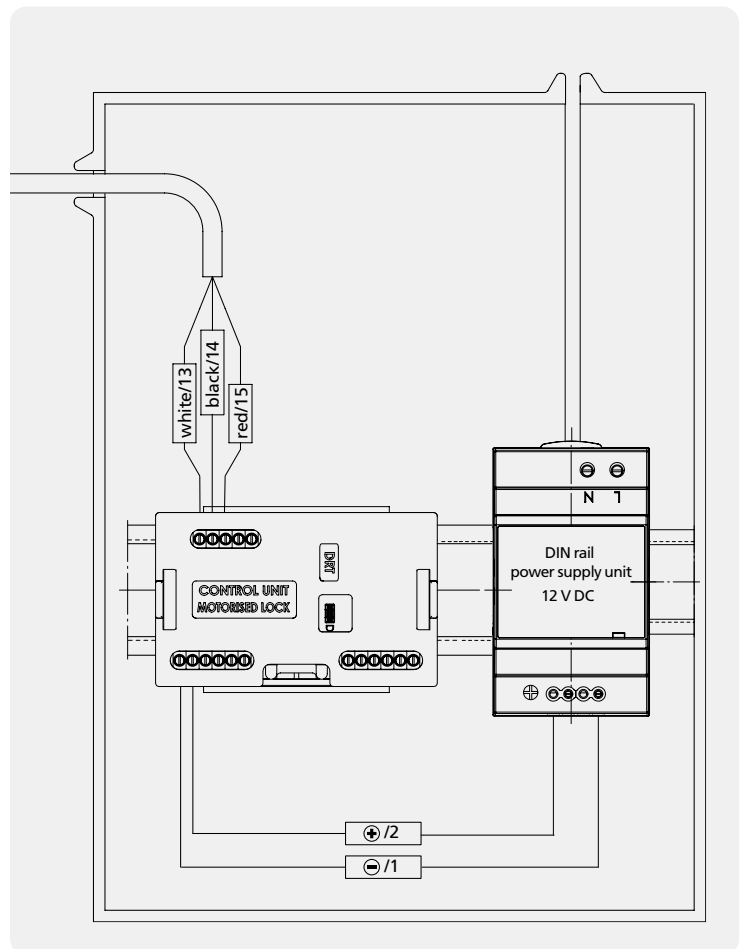

3.6 VERSION 6 – PROJECT – ALL-INCLUSIVE WITH CONTROL BOX

Functions:

- Opens via FUHR radio-controlled access control modules such as radio key, fingerprint scanner or transponder
- Integration in facility management systems
- Connection to external access control systems
- Connects up to an alarm system
- Connects up to a swing door opener
- Connects up to time switches (permanently-open function)
- Connects up to external indicator LED Art. no. NZ80067
- Input signal to electronically disconnect the access control systems for alarm systems

System components:

Multipoint locking system
FUHR autotronic 834
or autotronic 836
 incl. electromotive drive unit



Profile related one-piece system strike plate + to be ordered separately:
contact magnet for the motor drive
 (Art. no. VNZM14195)
and magnet release for type 4 resp. type 10
 (Art. no. depending on version)



Profile related tappet contacts

Cable connector (length 4000 mm) with preassembled multi-functional jack

Contact surface

Cable connector (length 250 mm) preassembled



Control box with integrated mains adapter and master radio key

Art. no. VNZASTP043



Cable protection elements for secure cable laying:

Cover plate | 2 m | F16 – Art. no. VNZ33171X |

F20 – Art. no. VNZ33172X | F24 – Art. no. VNZ33173X

Double cable guides for Euro-groove – Art. no. VNZ13845

End caps for cover plate | F16 – Art. no. VNZ13846 |

F20 – Art. no. VNZ13847

Cable protection sleeves – Art. no. VNZ80022



Principle of connection with type 4 (type 10 analogue)

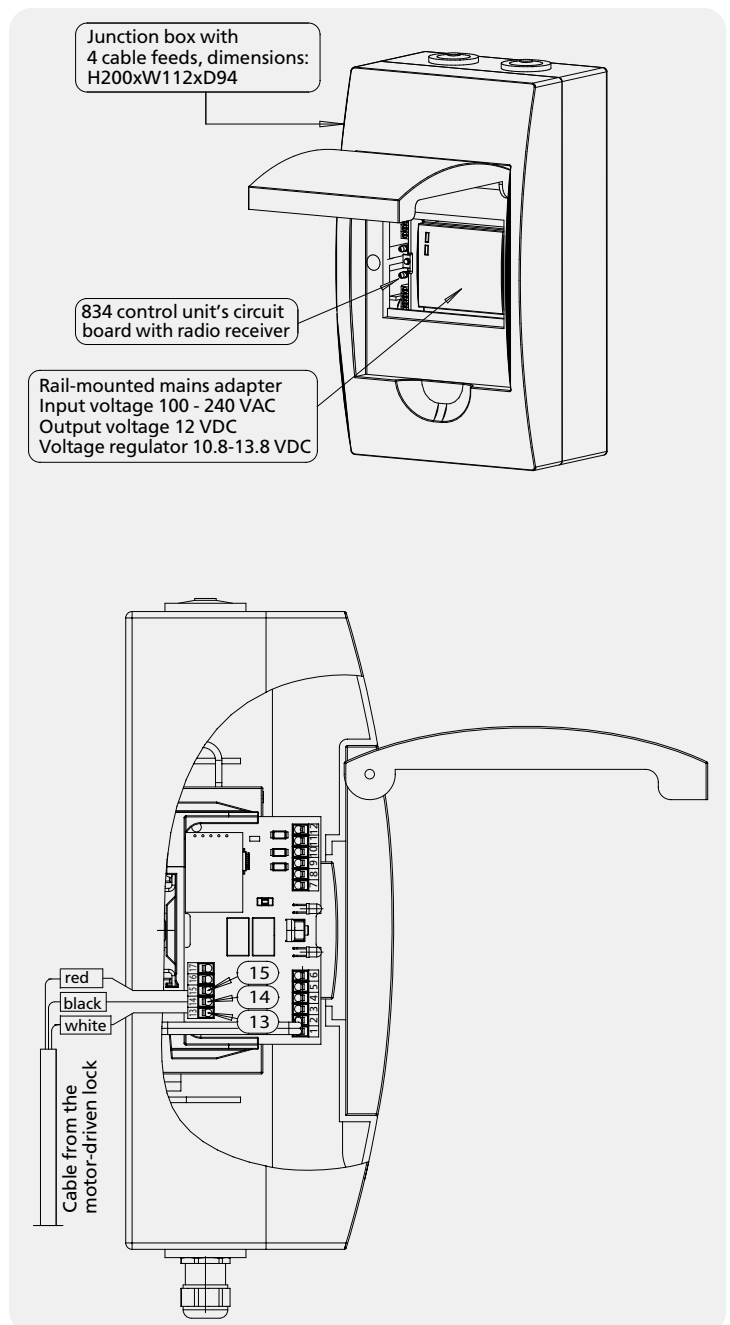

4 Installation instructions

4.1 ROUTING AND DRILLING OPERATIONS

Make cut-outs for the multipoint locking system FUHR **autotronic** 834 or **autotronic** 836 and for the matching one-piece or standard strike plates.

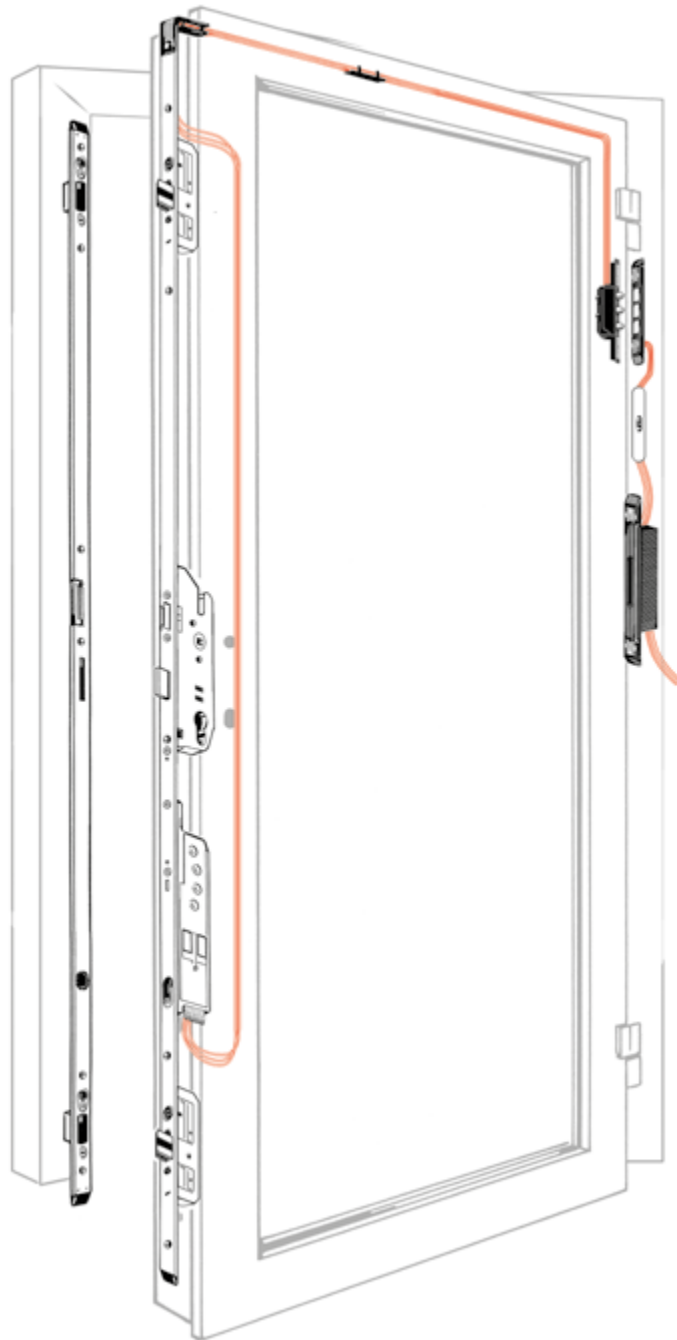

The illustration shows the door from the inside.
Always mount the control unit on the inside.

4.1.1 CABLE-LAYING DEPENDING ON THE DOOR DESIGN FOR ALL INSTALLATION VERSIONS

Version A – e.g. for PVC doors:

Cable-laying in the Euro groove.



Deburr the cable feedthrough hole and insert the cable protection sleeves provided.

Version B – e.g. for aluminium doors:

If the cable is to be laid in the glazing rebate's Euro groove, a Ø 10 mm drill hole is to be drilled in the glazing rebate area.



Deburr the cable feedthrough hole and insert the cable protection sleeve provided.

The 230 V electricity cable is a surface-mounted cable. Conduit must be used for concealed cabling. The door frame must be earthed/grounded.

The cable-laying for version A is described in the following installation steps.

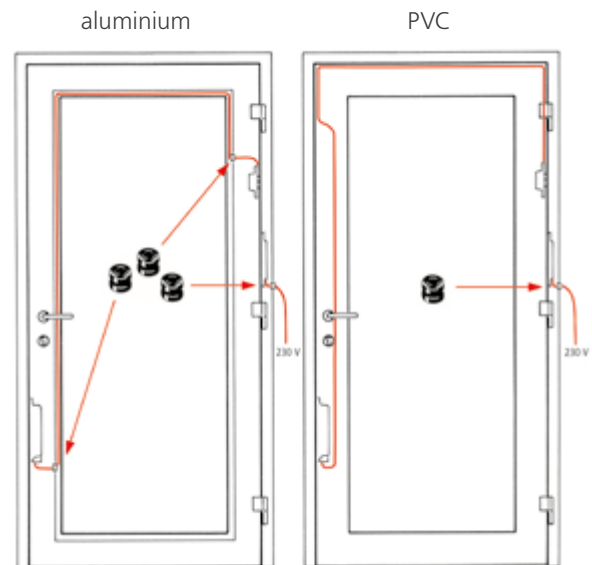

4.1.2 ROUTING FOR THE ELECTRONIC DRIVE UNIT IN THE DOOR LEAF

Routing in compliance with the separate routing drawing between the main lock and the bottom additional locking point.

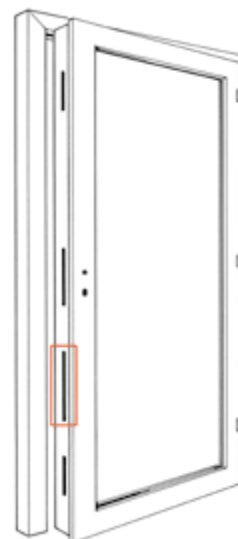

4.1.3 ROUTING FOR THE TAPPET CONTACTS IN THE DOOR LEAF ON THE INSTALLATION VERSIONS 2 -6

Routing on the hinge side of the door leaf



Make sure that the surface-contact device and the tappet contact device are aligned accurately horizontally. Refer to chapter 4.2.4.

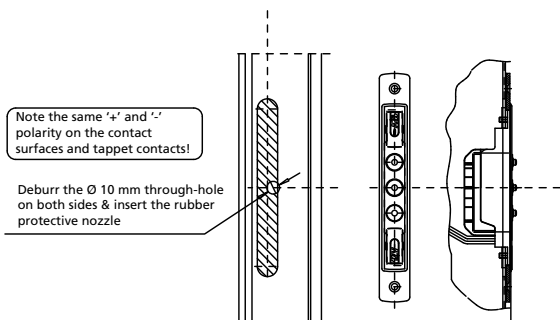

Exemplary routing. Please ask for the particular profile-related routing dimensions.



4.1.4 DRILL HOLE FOR THE SURFACE-CONTACT'S CABLE ON THE INSTALLATION VERSIONS 2 -6

Drilling in the frame profile, laterally at the same height as the tappet contact device



Care must be taken to ensure that the surface-contact device and the tappet contact device are aligned accurately horizontally. Refer to chapter 4.2.3.

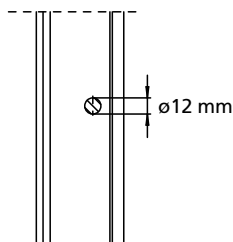

4.1.5 ROUTING FOR THE CONTROL UNIT CASING IN THE DOOR FRAME ON THE INSTALLATION VERSION 4

Routing on the hinge side of the door frame face **inside of the building**

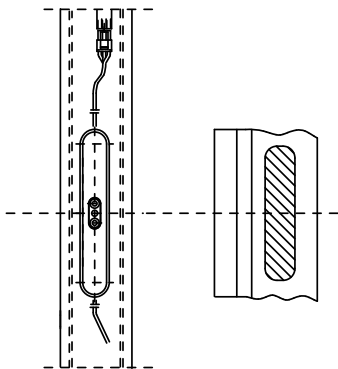

Exemplary routing. Please ask for the particular profile-related routing dimensions.



The illustration shows the door from the inside. **Always mount the control unit on the inside.**

4.1.6 ROUTING FOR THE SWITCHING POWER SUPPLY UNIT IN THE DOOR FRAME ON THE INSTALLATION VERSIONS 3 AND 4

Routing on the hinge side of the frame profile

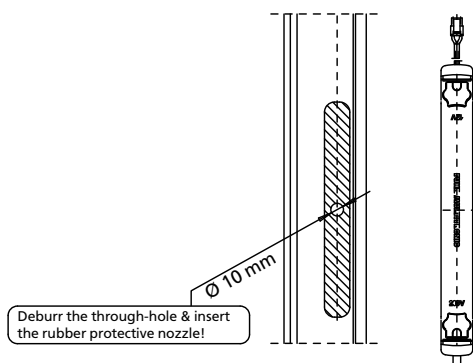

Exemplary routing. Please ask for the particular profile-related routing dimensions.



4.1.7 DRILL HOLE FOR THE 230 V CABLE ON THE INSTALLATION VERSIONS 3 AND 4

Drilling on the back of the profile within the cut-out for the switching power supply unit



This drill hole must be deburred carefully at both ends! Insert the cable protection sleeve provided in the drill hole to protect the 230 V cable. The cable must be protected against abrasion and securely fixed in order to prevent tractive forces.



4.1.8 SAFETY INSTRUCTIONS



All routing and drilling work must be deburred carefully. The cables must be securely fixed in this area in order to prevent abrasion. All routing and drilling swarf must be carefully removed from the profiles.

4.1.9 SCREWS FOR FIXING INDIVIDUAL COMPONENTS

Conventional fenestration screws with a maximum screw head diameter of 7 mm and a maximum screw diameter of 4.5 mm may be used. The PVC components (switching power supply unit, surface-contact device etc.) are to be fixed with screws with a **maximum length of 20 mm**. To fix the metal components (faceplates, keeps etc.) select a screw length according to the requirements. Depending on the profile material, screw holes may have to be pre-drilled with an appropriate drill.

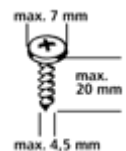

It is imperative that all screws are hand-tightened (maximum torque 1 Nm), as some components are made of PVC and may be damaged by the excessive force that a cordless screwdriver can exert.

It is essential that the surface-contact device and the tappet contact device are aligned accurately.

4.2 INSTALLATION

4.2.1 INSTALLATION ON INSTALLATION VERSION 4



The installation requires exceptional care. This applies particularly to the electronic components, as routing and drilling swarf, abrasion points, defective cables and damaged contacts etc. can lead to the device malfunctioning.

Avoid positioning fixing materials (e.g. frame-fixing screws) in areas where electronic components are located!

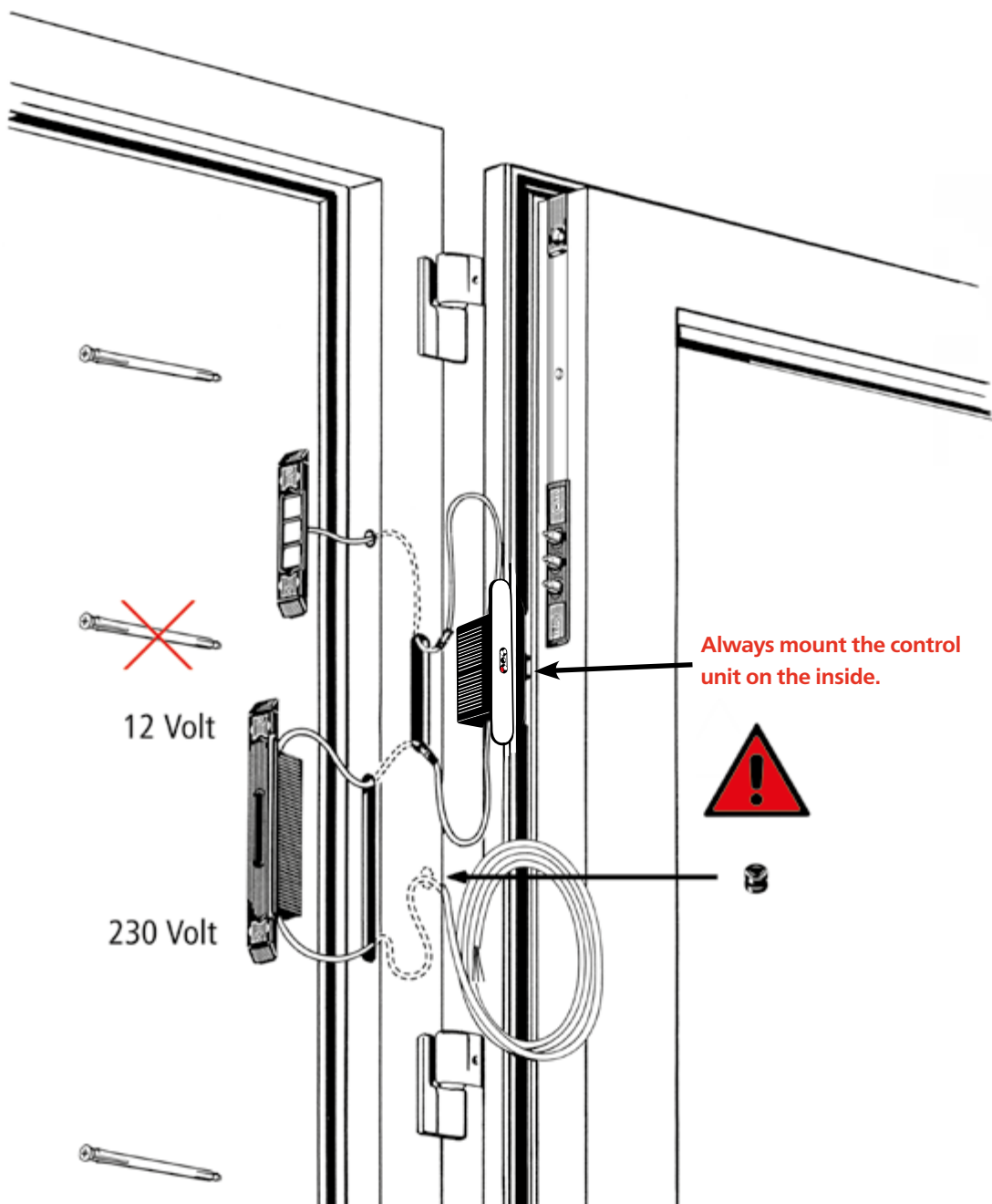

4.2.2 INSTALLATION OF THE TAPPET CONTACTS

The electricity and data transfer control unit of the FUHR **autotronic** can be used for left handed as well as right handed doors.

On right handed doors the tappet contact device is installed as supplied.

On right handed doors the cable is placed in the guide channel on the rear side of the casing.



Check the polarity (plus/minus) before installing the tappet contacts, refer to the component's identification marking:

DIN right = Plus symbol on the bottom
DIN left = Plus symbol on the top

1. Remove the silver covers from the tappet contact device.
2. Insert the tappet contact device into the door leaf's routed recess.
3. Lay the cable with the green plug in the channel above the door.
4. Screw-fix the casing to the door leaf profile.
5. Replace the covers.
6. Insert the green plug in the additional locking point's top routing and lead it down to the routed recess for the electrical drive unit.

DIN right



DIN left

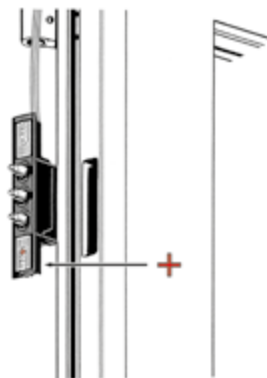

DIN right

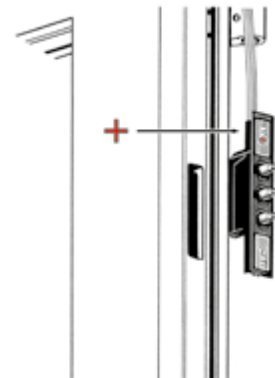

DIN left

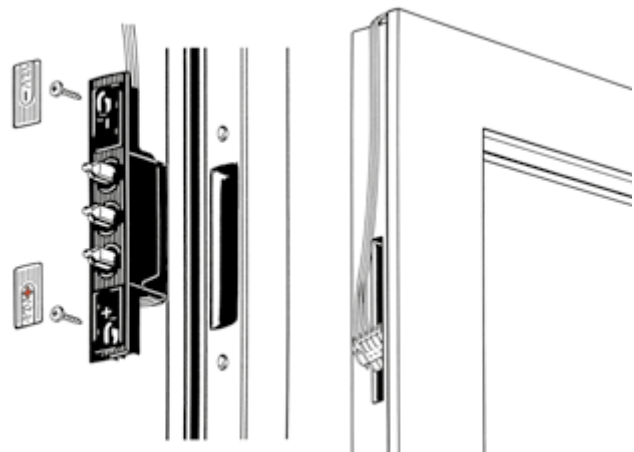
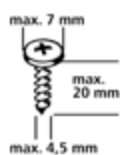

4.2.3 INSTALLATION OF THE MULTIPOINT LOCKING SYSTEM IN THE DOOR LEAF

1. Connect the tappet contact device's green plug to the corresponding contact plug on the electrical drive unit. As the case may be, please note deviating cable assignment on the multifunctional jack when using this without a control unit, refer to chapter 3.
2. Screw-fix the plugs with a small screwdriver.



Please note! It is imperative to carry out this screw-fixing. The screw-fixing warrants permanent contact for the electricity and data transfer, and safeguards against vibration and shock.

3. Insert the cable and FUHR **autotronic** 834 or 836 multipoint locking system into the routed recess. Leave a **spare cable loop** below the green drive unit's coupler in the profile in order to be able to remove the lock at a later stage.



In doing so, ensure that the cables are neither kinked, trapped nor damaged.

4. Screw-fix the multipoint locking system's faceplate. Fix the screws in a straight manner in order to prevent the connecting-rods being jammed by the screws.



Please note! The connecting-rods have to be able to move unhindered. Friction caused by screws or too narrow profile guide grooves cause operational malfunction.

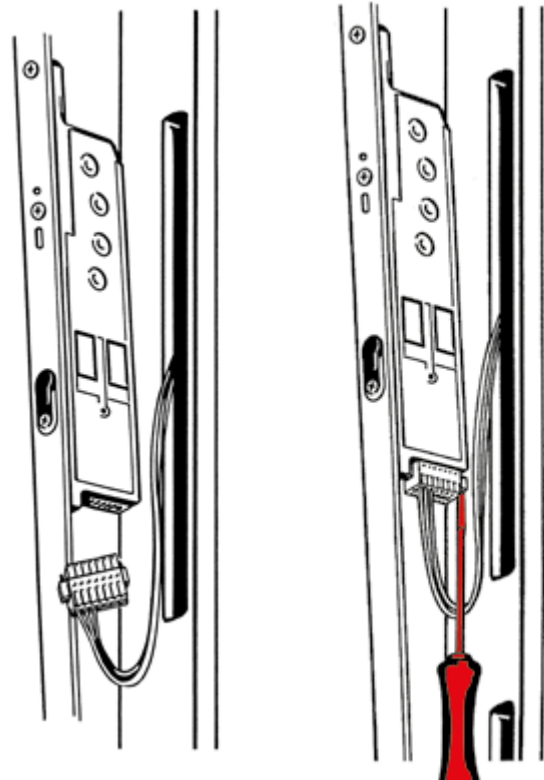

4.2.4 INSTALLATION OF THE CABLE GUIDES, END CAPS AND COVER PLATES IN THE DOOR LEAF

1. Fold the enclosed PVC cable guides for the profile corners in half and break them in two for the centre profile area.
2. Clip in each of the cable guides into the top door leaf corners, and depending on the door width and height, also in the Euro groove channel.
3. Lay the cable through the cable guide and loop the surplus cable between two cable guides.
4. Crop and screw-fix the cover plate according to the door width or height.

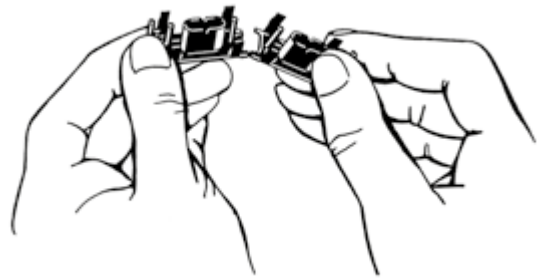

Ensure that the screws are screw-fixed through the cable guides' elongated holes. Non-compliance can lead to damaged cables.

5. Put on the end caps and screw-fix through the cable guides.

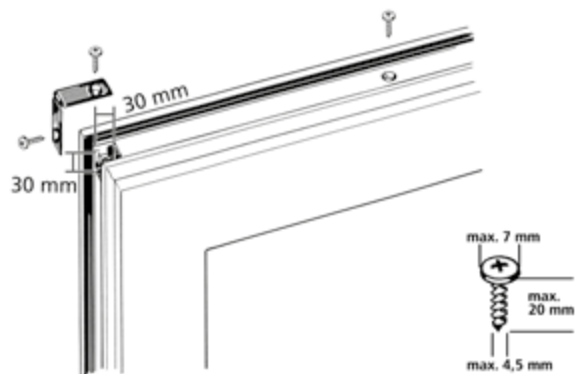
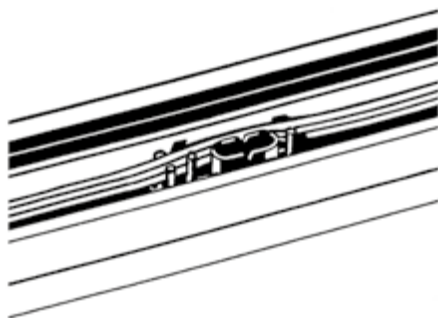
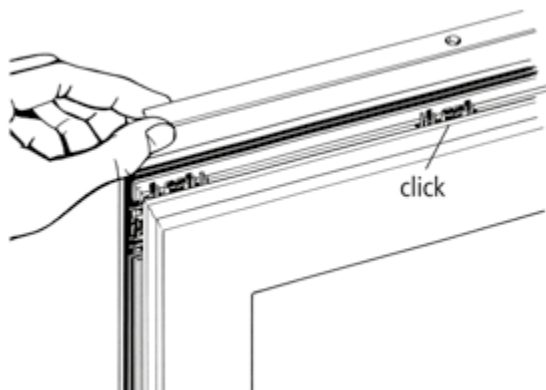

4.2.5 INSTALLATION OF THE MAGNETIC CONTACT IN THE DOOR FRAME

1. Install the magnetic contact in accordance with the supplied routing drawing. The exact drawing dimension must be adhered to in order to warrant perfect contact with the electromotive drive's reed switch.



Make sure that the reed switch and magnet are aligned horizontally at the same height.

For one-piece keeps:

The installation of the one-piece keep is to be carried out in compliance with the routing drawing. The magnetic contact must be ordered separately (Art. no. VNZM14195) and installed.

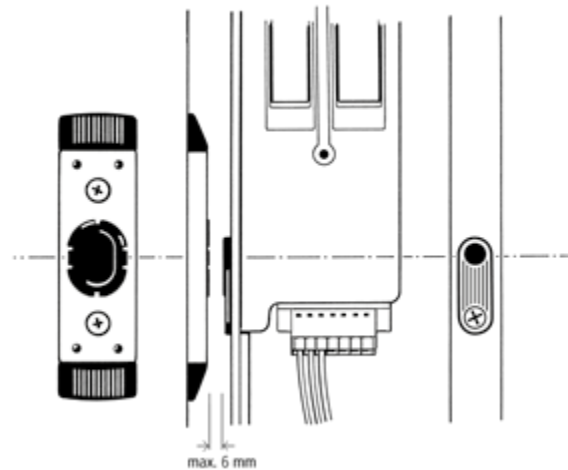

4.2.6 INSTALLATION OF THE SURFACE-CONTACT DEVICE IN THE DOOR FRAME

1. Remove the silver covers.
2. Feed the surface-contact device's 3-core cable (red, black, white) through the frame profile's drill hole and back outside through the control unit casing's routed opening. Pull the cable all the way through the routed opening so that the surface-contact device is located level on the profile.
3. Screw fix the surface-contact device to the frame profile.
4. Replace the covers.



In order to ensure proper contact and durable operation, the contact surface has been pre-treated with contact lubricant. Please do not remove this lubricant film! Adhere to the regular maintenance instructions in compliance with chapter 9.1.

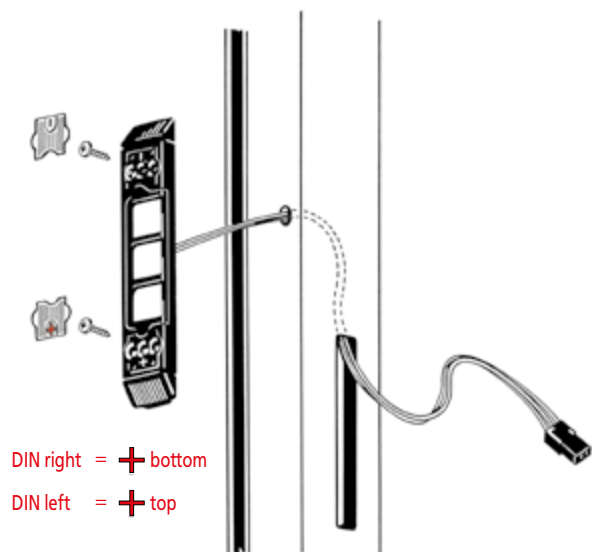

4.2.7 INSTALLATION OF THE CONTROL UNIT HOUSING IN THE DOOR FRAME

1. Remove the stainless steel cover before mounting the control unit housing. This is held by two magnets and can be easily removed. To do this, carefully grasp the recess in the cover plate with a small screwdriver or fingernail and remove the cover plate.
2. Connect up the surface-contact device's 3-core cable plug (red, black, white) with the control unit casing's 3-core cable plug. The plug clicks in audibly.
3. Insert the 2-core control unit casing cable into the routed recess, guide the cable downwards, and exit through the switching power supply unit's routed recess.
4. Carefully feed the control unit casing's cable back into the frame profile so that the control unit casing fits comfortably in the routed recess.



Please ensure that the cables are neither kinked, trapped nor damaged by sharp profile edges.

5. Screw-fix the control unit casing into the frame profile.



Ensure that the cables are not damaged when screw-fixing.

6. Replace the control unit casing's cover cap.

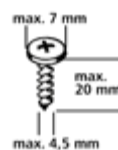
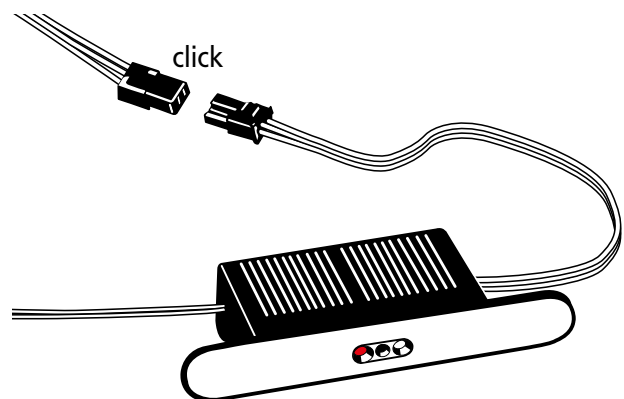
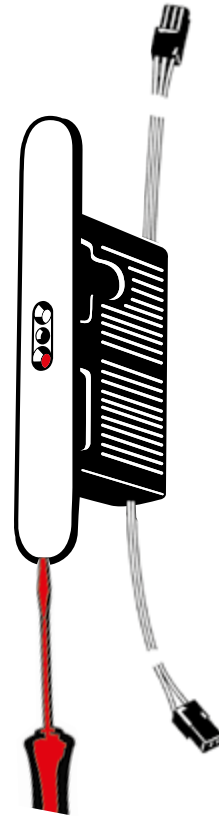

4.2.8 INSTALLATION OF THE SWITCHING POWER SUPPLY UNIT (TRANSFORMER) IN THE DOOR FRAME

The FUHR **multitronic's** switching power supply unit can be used for left handed as well as right handed doors. **On right handed doors** the switching power supply unit is installed as supplied.

On left handed doors the top profile-related end cap is swapped with the bottom one.

1. Remove the silver covers.
2. The green/yellow earth cable is to be electroconductively connected with the door's metal frame.
3. Connect up the control unit casing's 2-core cable (red/black) with the switching power supply unit's cable counterpart. The plug clicks in audibly.

4. Feed the cable carefully back into the frame profile, **ensuring that the switching power supply unit fits comfortably into the routed recess.**



Depending on the profile type, loop the cable at the bottom of the profile.

5. Guide the 230 V cable out through the deburred drill hole at the bottom of the profile (through the inserted cable protection sleeve). Leave a **spare cable loop** in the profile in order to be able to remove the switching power supply unit at a later stage. Fix the rolled up cable to resist tractive forces and fasten it to the outside of the door frame using a cable tie.

6. Screw-fix the switching power supply unit to the frame profile (maximum torque 1 Nm).



Ensure that the cables are not damaged when screw-fixing. Earth the frame before commissioning.

7. Replace the covers.

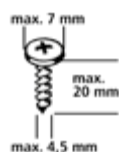
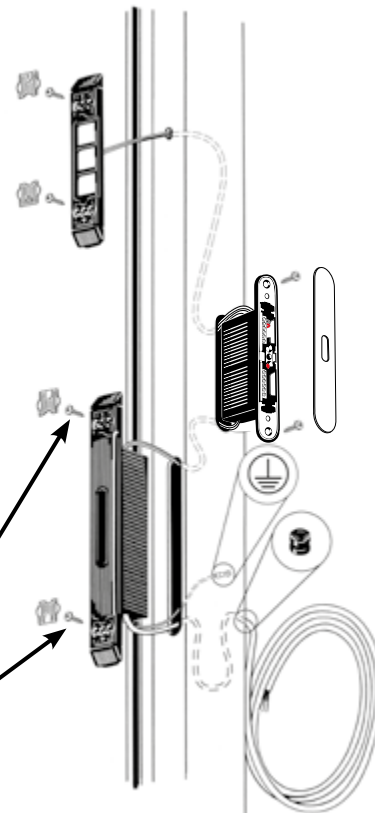
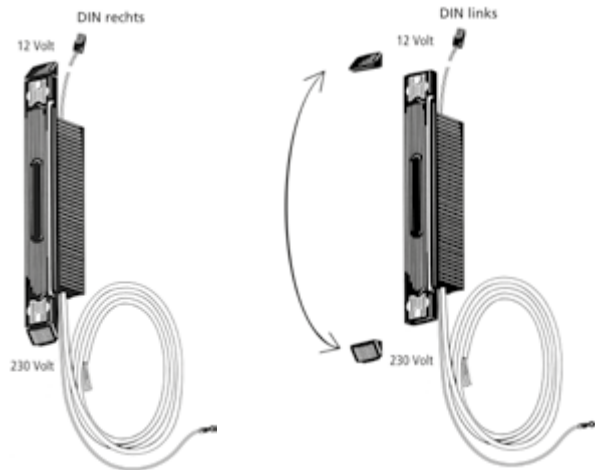

5 Commissioning

5.1 OPERATION VERIFICATION CHECK ON THE FABRICATOR'S PREMISES



1. After all of the FUHR autotronic components have been installed, check that the doorflügel und -rahmen parallel zueinander ausgerichtet sind.

2. Install a profile cylinder in the centre lock.
3. Subsequently connect the 230 V cable to the mains voltage by means of a two-pin earthed plug for testing purposes (only to be carried out by qualified personnel).
4. The green LED will light up as soon as the operating voltage is applied. Upon closing over the door, the latching deadbolts or the latching and hook bolt combinations extend 20 mm. The lock is now automatically locked and the red LED lights up.
5. In order to test all functions, the door should be opened and locked several times in the door factory via the drive unit, the profile cylinder, and via the lever-handle. In the event of any problems arising, please proceed in accordance with Chapter 11.
6. If the FUHR **autotronic** lock is fully operational, the two-pin earthed plug can be removed and the door can be despatched.

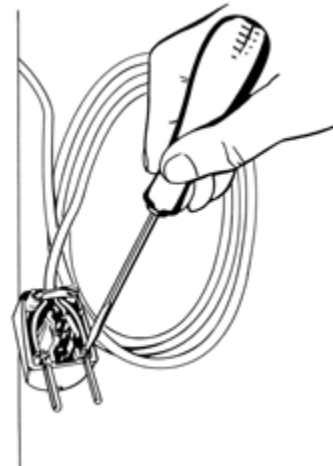
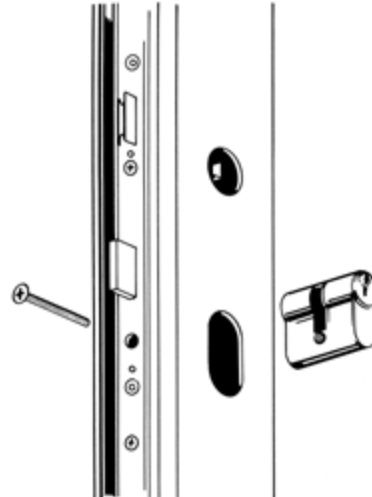

5.2 COMMISSIONING ON SITE



1. Install the door in the wall opening in the usual manner, guiding the 230 V cable to the internal side of the wall. Make sure that fixing materials (e.g. wall anchors) are not located where the electronic components are.
2. An electrician must connect up the 230 V cable to the power supply. The door frame's earthing/grounding is to be professionally checked. Conduit must be used for 230 V concealed cabling.
3. In order to be able to warrant the power supply of all electronic components, also in the case of a network operator's power failure, fire doors in accordance with DIN 4102 and DIN EN 1634 should be equipped with an emergency power supply!

5.3 SETTING POSSIBILITIES

A reliable function of the door system is only guaranteed if lock and door have been installed correctly and **hinges and one-piece/standard strike plates** have been adjusted correctly. In order to achieve an optimal tightness of the door, the **one-piece/standard strike plates** can be adjusted as follows:

One-piece/standard strike plates with magnet

Adjustment of one-piece/standard strike plates

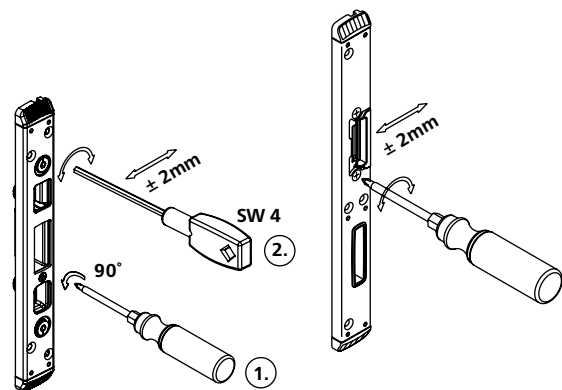
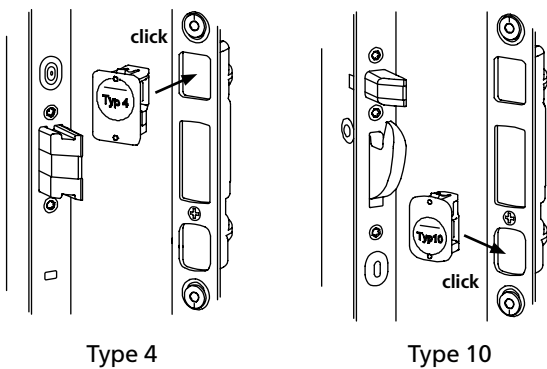

Latch conversion Type 4/10

Latch conversion (Coinversion to soft latch/reduced latch)

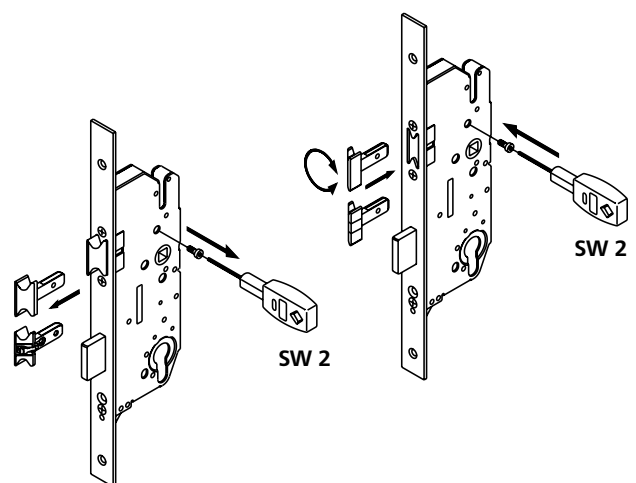
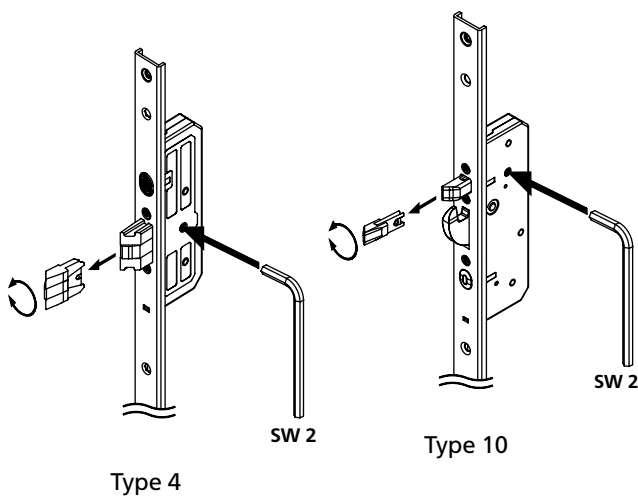

6 External connection options

The FUHR **autotronic** multi-functional control unit is equipped with an integrated radio receiver as standard as well as a large number of inputs and outputs for connecting further components such as transponders, eye scanners, fingerprint scanner, code locks, swing door drives, alarm systems, building management systems, etc. (see chapter 6.2).

In addition, the **multi-functional jack** on the FUHR **autotronic** motor drive provides further inputs and outputs for the connection of e.g. access control systems, illuminated push buttons or glazing elements (see chapter 6.3).

Frame-mounted control



Rail mounted control



Control box with integrated mains adapter



6.1 THE RADIO RECEIVER MODULE

If only a radio signal is required to open the door, the radio receiver module can be used as an alternative to the control unit (for lockd from date of manufacture 04/2010).

The radio receiver module NBF490 **(1)** receives the radio signal and forwards it to the motor for door opening. It has a transparent programming button with red control LED **(2)** for pairing the FUHR radio transmitters and a 3-wire connection cable **(3)**, which is connected to the green plug of the motor drive.

To position and fix the drive unit, the radio-controlled module's housing is equipped with an insertion channel and a catch spring **(4)**. The drive unit is equipped with appropriate mounting areas. Slide the radio receiver module downwards along the insertion channel until the catch spring in the motor drive's housing positively engages into place.

There is an opening **(5)** in the lock faceplate located above of the drive unit, through which one can activate the LED tune-in button **(2)** in a built-in state from the outside with a thin object. This LED tune-in button must be pressed first for disassembly, before the radio receiver module can be removed towards the top.

Connecting the cables

Three cables are located on the back of the radio receiver: white, brown & green. Please connect these three cables in the correct arrangement to the following screw terminals of the multifunction plug of the motor drive:

- Terminal 4 – white cable
- Terminal 5 – brown cable
- Terminal 6 – green cable

After the motorised lock's 12 V DC power supply has been connected (terminal 2-3 refer to page 6.3), the radio receiver is operational.



Detailed **installation, operating and maintenance instructions MBW24** of the radio receiver module VNBFP490: www.fuhr.de

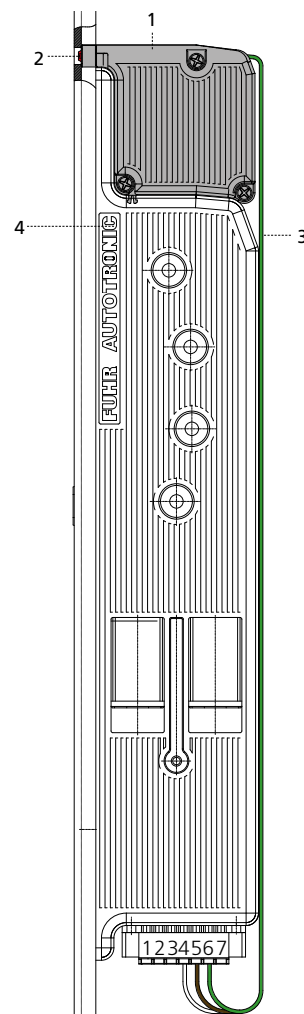
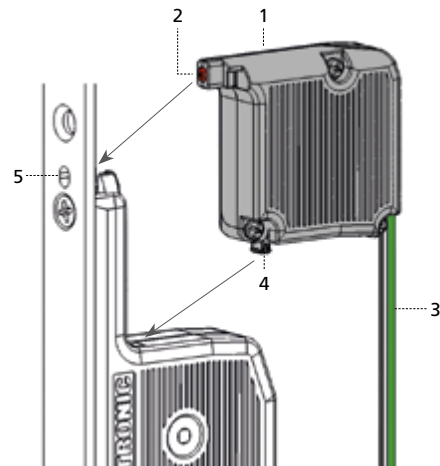

6.2 THE CONTROL UNIT

In addition to many other connection options, the multi-functional control also offers the use of a permanently-open function in which the latch and all bolts are permanently retracted. This allows the door to be opened unhindered from both sides – without access control.

This function can be realised in two different ways:

- **Cable connected** – via an external or optional available switch(see chapter 6.2.1)
- **Wireless via radio signal** – via a radio key or with another FUHR access control system (see chapter 6.2.2)

A combined application of both variants is not recommended, or should only be carried out by qualified personnel and checked beforehand on the basis of individual customer requirements.

The LEDs on the control unit indicate the set function:

Permanently-open function: green LED flashes slowly

6.2.1 Cable connected permanent unlocking

Enables manual activation of the permanently-open function (terminals 9 + 10).



Control switch for activating special functions

Stainless steel cover plate with slide switch and connecting cable, for retrofitting the mounting control.

Art. no. VNZSTZ0459

6.2.2 Wireless permanent unlocking via radio signal

Enables activation of the permanently-open function via radio key or via other FUHR access control systems, available from software version SW 1.40 (see chapter 6.2.4).



4-channel radio key with wall bracket

Easy mounting at a suitable location inside the building, high transmission range, including battery with long life.

Art. no. VNZ80293

6.2.3 Connecting possibilities of the control

In the following, the assignment possibilities of the connection terminals of the control unit are described as an example:

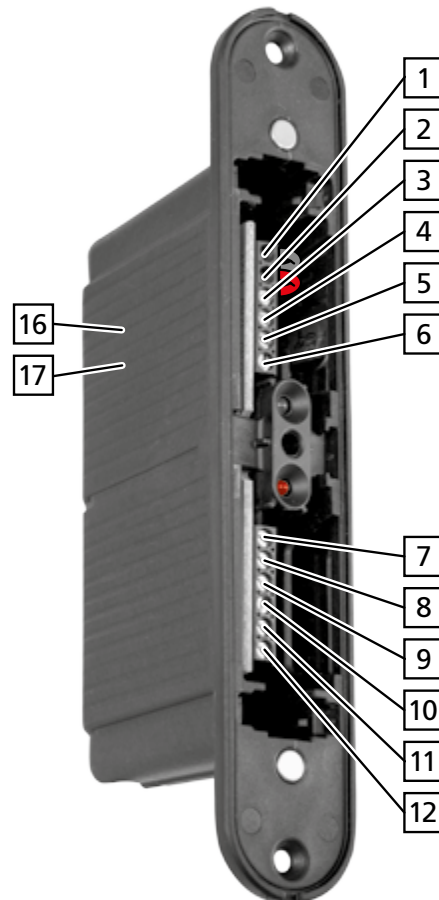

Terminal/ Function	Assignment
Grid 1 (GND) + 2 (+12 V)	Stabilized power supply 12 V DC $\pm 4\%$.
Outputs 3 + 4 Switching output	<p>Output, e. g. for electric swing door drives</p> <p>Make contact</p> <ul style="list-style-type: none"> • Function 1: Immediately after the FUHR autotronic lock has been opened via radio control, transponder etc., a relay triggers the make contact for 1 second. This impulse is processed by the swing door opener's control unit and triggers the swinging movement of the door leaf. • Function 2: The 'DRT' jumper can be removed if required (refer to the wiring diagram on page 41), enabling the swing door opener's output to be triggered just as long as a continuous signal is applied to the latch retaining function (terminal 9 + 10).
5 + 6 Alarm output	<p>Output door leaf position, e. g. for alarm systems</p> <p>Break contact</p> <p>Unlocking the lock and opening the door leaf triggers the related opener contact within 1 second. This remains triggered until the door leaf is closed. An alarm system control unit digitally processes the signal status and reports back 'OPEN' or 'CLOSED'.</p>
Inputs 7 + 8 Door opening	<p>Input 6–12 V AC / 6–24 V DC</p> <p>For non-isolated opening pulses by access control systems, e. g. of intercom or building control systems.</p>
9 + 10 Door opening	<p>Input potential-free</p> <p>For potential-free opening pulses by access control systems for short-time and permanent unlocking:</p> <ul style="list-style-type: none"> • Function 1: Standard opening If a potential-free impulse ≤ 1 second is applied to this input (e.g. controlled via an access control system), the FUHR autotronic lock will open. • Function 2: Permanently-open function If a potential-free continuous signal is applied to this input (e.g. controlled via a time switch) the FUHR autotronic lock will open. All locking components remain completely withdrawn as long as the continuous signal is applied. When using or, in particular, when switching off the permanent unlocking, it must be ensured that the latching deadbolts retract freely into the strike plates.
11 + 12 Door opening	<p>Input potential-free</p> <p>If a potential-free impulse is applied to this input (e.g. controlled via an access control system), the FUHR autotronic lock will open.</p>
16 + 17 Deactivation	<p>Input potential-free</p> <p>For the duration of the pending signal, all motor opening functions (control: radio receiver and input terminals 7–12 / control in motor drive: terminals 4 and 7) are deactivated, e. g. to prevent the motorized door opening after arming an alarm system. The red LED of the control unit and, if applicable, the connected external control LED flash permanently.</p>
Jumper DRT	If the jumper DRT is removed , the output at terminal 3 + 4 remains connected as long as a continuous signal at terminal 9 + 10 is applied.
Radio receiver	For opening pulses via FUHR rolling code access control systems , refer to page 35 ff.

6.2.4 WIRELESS CONTROL OF THE PERMANENTLY-OPEN FUNCTION VIA RADIO SIGNAL | TUNING IN A RADIO KEY

(available from software version SW 1.40)

Instead of the radio key VNZ80293 shown here as an example, any other FUHR radio access control system can be taught in for activation.

PERMANENTLY-OPEN FUNCTION



1. Carefully press the programming button on the control unit for about **10 seconds**. As soon as the red and green LED flash release the programming button.

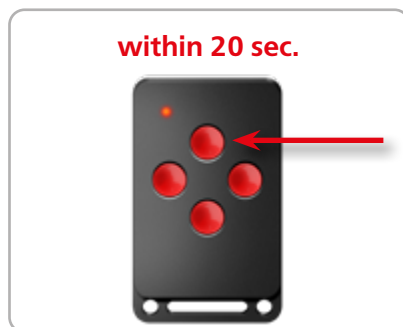

2. Now press the master key's front, middle button **within 20 seconds**.

» If the control unit accepts the master key, the green LED lights up for 3 seconds and then continues to flash quickly.

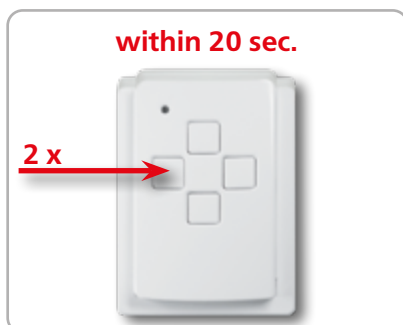

3. **Within 20 seconds**, press a key of the radio key to be paired **twice** in succession. The tuning in procedure is aborted if the 20 second time limit is exceeded.

» If the control unit accepts the new radio key, the green LED lights up for 3 seconds.

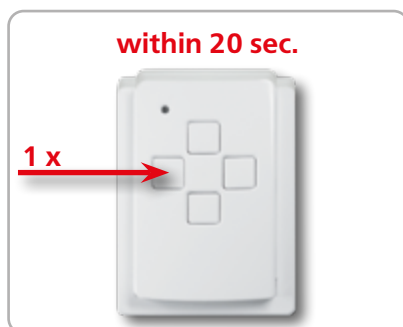

4. If you want to activate or deactivate the permanently-open function, press the send button on the radio key **once**.

» When the **permanently**-open function is activated, the green LED of the control unit flashes slowly.

6.2.5 APPLICATION EXAMPLES FOR CIRCUIT BOARD ASSIGNMENT

Application example – two-way intercom system:

For example the door shall be opened via radio key from the outside.

The opening is triggered from the inside by means of an existing two-way intercom system with a 12 V AC control cable. This was, as the case may be, used previously for an electrical door opener.

Terminal assignment:

Connect the two-way intercom system's cables to terminal 7 + 8.

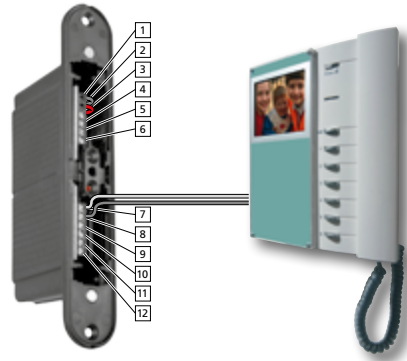

Application example – external access control:

The opening shall be triggered from the outside by means of an access control system (e.g. numeric code lock or finger print).

Terminal assignment:

Connect up the access control system with potential-free impulse to terminals 11 + 12.

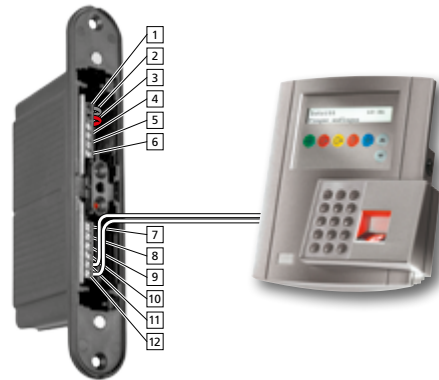

Application example in construction projects:

For example: the door is switched to the 'permanently-open function' in the 'day operation mode', in the 'night operation mode' the lock shall always lock both completely and fully automatically.

Opening from the outside is triggered by means of an access control system (e.g. numeric code lock or transponder). In addition, an electrical swing door opener shall automatically open the door leaf and the door leaf setting for the alarm system is monitored.

Terminal assignment:

Connect the time switch with potential-free continuous signal to terminals 9 + 10 for function 2.

Connect the access control system with potential-free continuous impulse to terminals 11 + 12 for function 1.

Connect the swing door opener to terminals 3 + 4. Connect the alarm system to terminals 5 + 6.

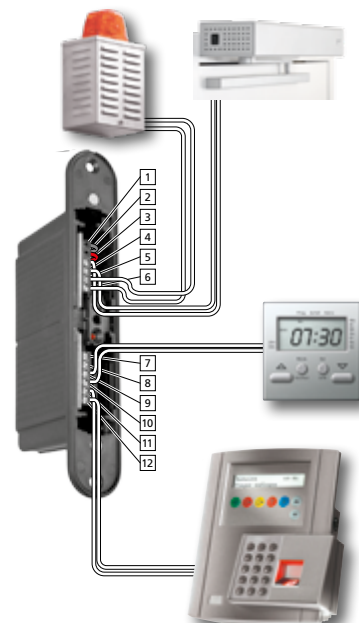

6.3 THE DRIVE UNIT'S MULTI-FUNCTIONAL JACK

The below-mentioned applications are merely intended as application examples of common connections. Furthermore there is a multitude of other possible applications.



It is important that the respective switching signal (e.g.: the 12 V DC impulse or the potential-free contact etc.) is connected to the appropriate terminal.

Terminal

Assignment

1 + 2 + 3

Already occupied by the 12 V DC drive unit's power and data supply cable.

4 + 5

Input (impulse < 1 second) – e.g. for **external access control systems (transponders, code locks, finger print, eye scan etc.)**, that are mounted directly on the door leaf.

- The FUHR **autotronic** lock opens motor-driven by means of a potential-free impulse from the two-way intercom system or the access control system.

5 + 6

Output ideally used for the power supply of **illuminated fixed pad handles or illuminated glazed panels.**

- Terminal 5 = GND (earth) and terminal 6 = 12 V DC (max. 350 mA).

5 + 7

Input (impulse < 1 second) – e.g. for **external access control systems (transponders, code locks, fingerprint recognition, eye scanners etc.)**, that are mounted directly on the door leaf.

- The FUHR **autotronic** lock opens motor-driven by means of an energised impulse from the two-way intercom system or the access control system.
- Terminal 5 = GND (earth) and terminal 7 = 6-12 V AC or 6-24 V DC.

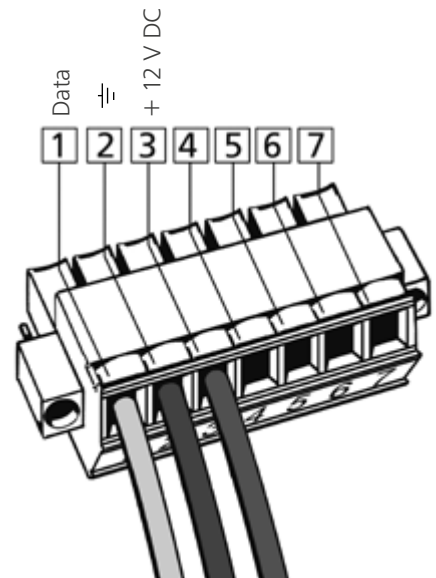

Reverse polarity causes damage!!



We recommend the use of shielded cables in order to avoid interference from external sources and ensure proper functioning.

8 Control via FUHR radio access control systems



factory-tuned

Each control unit comes with a radio receiver. To the scope of delivery of a control unit or a radio receiver module a master radio key with red buttons is included. With the help of the master radio key, 25 user radio control keys or any other FUHR access system can be tuned in. All radio keys are copy protected by means of a 'rolling code system'. The middle button of the master key has already been programmed to the control unit or the radio receiver module in the factory.

In the following, the pairing and deletion of 4-channel radio keys is described. Each of the keys (channels) can be assigned individually, e.g. for front door, garage door, property gate and lighting.

The handling of other FUHR radio transmitters (finger scan, keyboard, transponder etc.) is analogous. Detailed information: www.fuhr.de.

For the connection of external access controls, please refer to the wiring diagram in chapter 10 and the corresponding instructions.



The master key cannot be deleted or switched at a later stage. It should therefore be kept safely, as additional keys cannot be tuned in or deleted should it be lost.

8.1 THE PROGRAMMING KEYS

DIN rail controller

Integrated radio receiver

Radio receiver module



Programming button



LED-Programming button



8.2 TUNING IN AND DELETING USER RADIO KEYS

8.2.1 TUNING IN INDIVIDUAL USER RADIO KEYS (MAX. 25)



For safety reasons, we recommend that you first delete all radio keys when starting up for the first time (see chapter 8.2.3). Then proceed as follows:

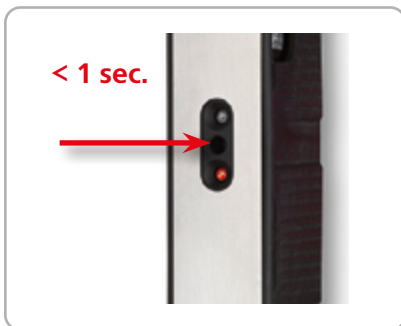

1. **Briefly (max. 1 second)** press the programming button on the control unit or radio receiver module with a thin object.

» The green LED (control) or the red LED (radio receiver module) flashes slowly.

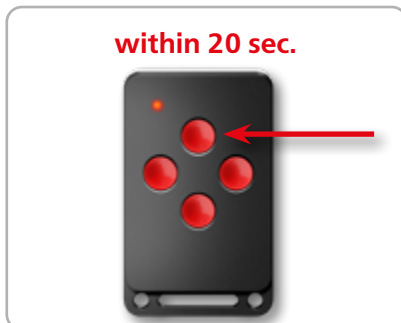

2. Now press the master key's front, middle button **within 20 seconds**.

» If the control unit or the radio receiver module accepts the master key, the green LED lights up for 2 seconds and then continues to flash slowly.

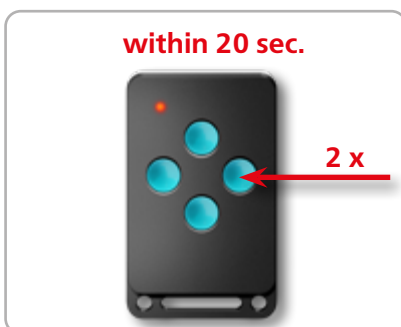

3. **Within 20 seconds**, press a key of the radio key to be paired **twice** in succession. The tuning in procedure is aborted if the 20 second time limit is exceeded.

» If the new radio key has been accepted by the control unit or the radio receiver module, the green LED (controller) lights up for 1 second and the red LED (radio receiver module) for 4 seconds.

4. Repeat from step 1, should you wish to tune in another radio key.

8.2.2 DELETING INDIVIDUAL USER RADIO KEYS

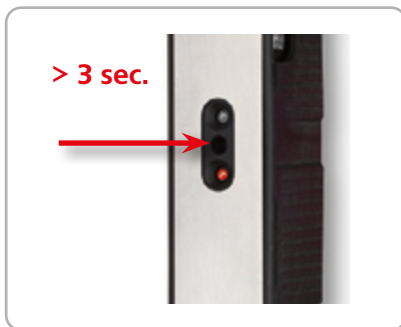

1. Press the programming button of the control unit or the radio receiver module **until (longer than 3 seconds) the green LED (control unit) or red LED (radio receiver module) flashes quickly.**

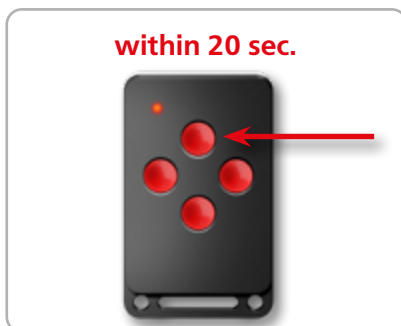

2. Now, press the front, middle button **within 20 seconds.**
 - » If the control unit or the radio receiver module accepts the master key, the green LED initially lights up for 2 seconds and then continues to flash quickly.

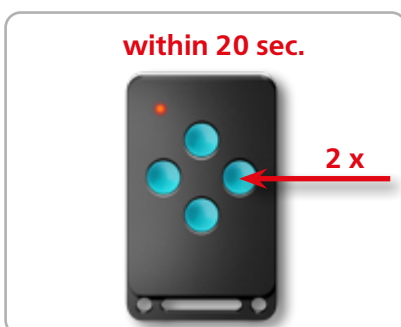

3. **Within 20 seconds**, press the corresponding key of the radio key to be deleted. The deleteprocess is aborted if the 20 second time limit is exceeded.
 - » If the transmission code has been successfully deleted, the green LED lights up for 1 second and then goes out.
4. Repeat from step 1, should you wish to delete another radio key.

8.2.3 DELETING ALL USER RADIO KEYS

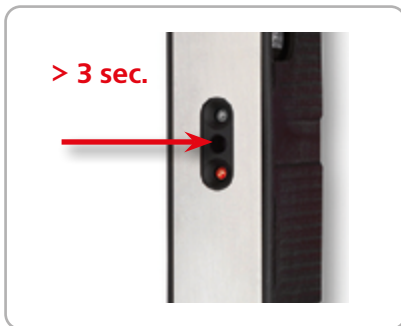

1. Press the programming button of the control unit or the radio receiver module **until (longer than 3 seconds) the green LED (control unit) or red LED (radio receiver module) flashes quickly**. Then release the button.

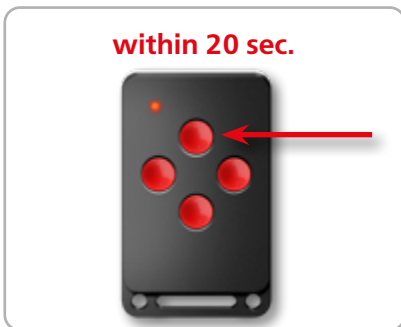

2. Now, press the front, middle button of the master key **within 20 seconds**.
 - » If the control unit or the radio receiver module accepts the master key, the green LED initially lights up for 2 seconds and then continues to flash quickly.

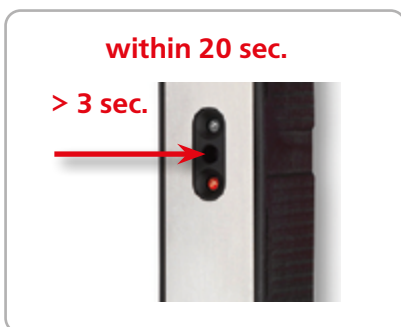

3. Now press the programming button on the control unit again **within 20 seconds** for **longer than 3 seconds**. The delete process is aborted if the 20 second time limit is exceeded.
 - » If all transmitter codes (except the master transmitter code) have been successful, the green LED (control unit) lights up for 1 second and the red LED (radio receiver module) lights up for 4 seconds.



Note:
If the master key is not recognised during the tuning-in and delete processes, the respective function is aborted.

9.1 CONTACT DEVICE



In order to ensure perfect contact between the contact surfaces and the tappet contacts, we recommend that the surfaces are treated with the provided contact lubricant twice a year. Lubricants from other suppliers are not suitable and therefore inadmissible.

(The contact lubricant can be reordered under Art. no. VNZ80077.)

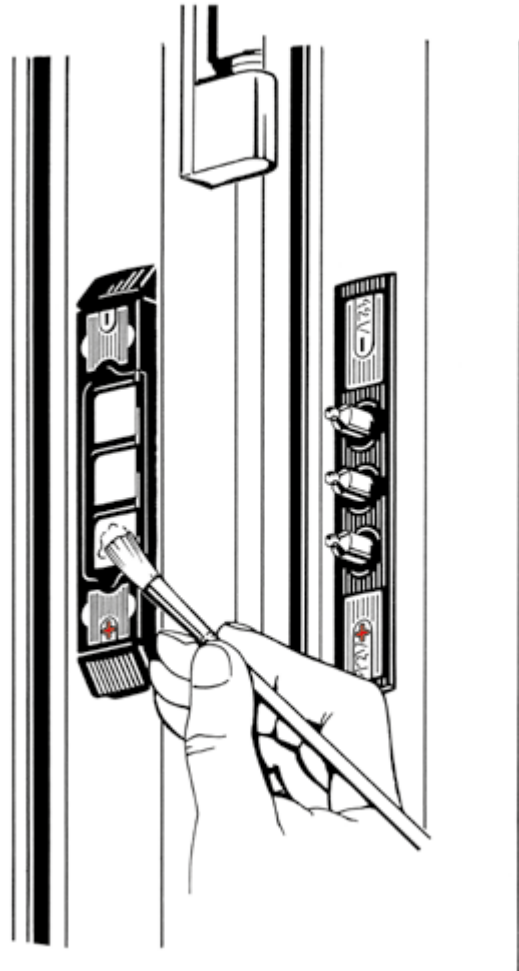

9.2 BATTERY CHANGE OF THE RADIO KEYS

The radio keys are particularly energy-saving and have a battery indicator light. The battery is sufficient for approx. 50,000 operations. Check the battery indicator light regularly to avoid failure. To change the 3- or 4-channel radio key battery, follow the steps below:

1. Carefully open the radio key housing with a coin (3-channel radio key) or a narrow object, e.g. a slotted screwdriver (4-channel radio key).
2. Push out the battery.
3. New battery (type: CR 2032). The plus symbol must point upwards.
4. Press the radio key housing together again.

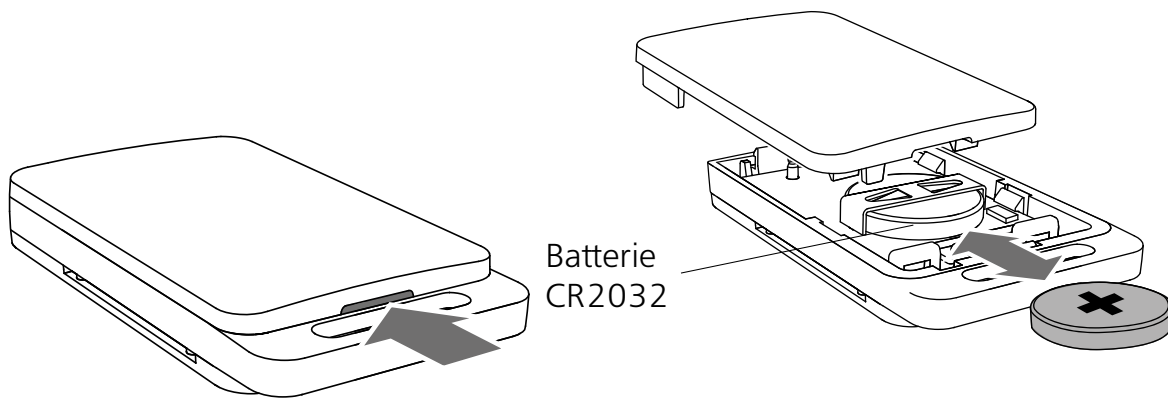

10 Technical data

10.1 MASTER-/USER RADIO KEY

The radio keys conform to the R&TTE guideline 2014/53/EU

Channel:	868.3 MHz
Modulation:	FSK (frequency shift keying)
Security:	Rolling code
Channels:	4
Power supply:	1 x 3 V battery, CR 2032
Operating control:	Red light emitting diode (LED)
Temperature range:	-10 °C to +50 °C
Dimensions:	61.5 x 37 x 10.5 mm
Weight:	Approx. 11 g.

10.2 RADIO KEY WITH WALL BRACKET

The radio keys conform to the R&TTE guideline 2014/53/EU

Channel:	868.3 MHz
Modulation:	FSK (frequency shift keying)
Security:	Rolling code
Channels:	4
Power supply:	1 x 3 V battery, CR 2032
Operating control:	Red light emitting diode (LED)
Temperature range:	-10°C to +50°C
Dimensions without wall bracket:	60 x 38 x 14 mm
Weight:	Approx. 25 g

10.3 FUHR AUTOTRONIC CONTROL WITH RADIO RECEIVER

Coding:	Not necessary as the transmission code will be tuned in
Channel:	868.3 MHz
Modulation:	FSK (frequency shift keying)
Aerial:	Cable aerial approx. 110 mm
Power supply:	12 V DC
Operating control:	2 light emitting diodes (LEDs)
Temperature range:	-10 °C to +50 °C
Dimension:	120 x 45 x 25 mm
Weight:	Approx. 75 g (incl. cable and casing)
IP rating:	IP 20
Alarm output:	Max. contact load capacity 125 V AC/1 A/62 VA

10.4 RADIO RECEIVER

Channel:	868.3 MHz
Modulation:	FSK (frequency shift keying)
Sicherheit:	Rolling code with master transmission principle
Aerial:	On board
Power supply:	12 V DC
Current consumption:	15 mA
Operating control:	Red light emitting diode (LED)
Temperature range:	-10°C to +50°C
Dimensions:	43 x 40 x 15 mm
Connection cable:	3-core, approx. 320 mm long
Weight:	Approx. 50 g
IP rating:	IP 20
Switching impulse:	Potential-free

10.5 FUHR AUTOTRONIC MOTOR DRIVE UNIT

Dimension:	50 x 206 x 15.5 mm
Weight:	Approx. 500 g. (only electrical locking unit)
Power supply:	12 V DC
Signalling:	1 piezo buzzer
Temperature range:	-10 °C to +50 °C
Contact rating terminal 6:	max. 350 mA (resetting fuse/PTC)

10.6 FUHR AUTOTRONIC SWITCHING POWER SUPPLY UNIT (INSTALLATION IN THE DOOR FRAME)

Model: Primary switching controller (single phase, primary clocked built-in power supply)
Impulse load capacity, short circuit protected, open-circuit proof, high efficiency, thermal overload protection

Tested in accordance with:	EN 60950
EMV:	EN 50081-2 (emitted interference) EN 61000-6-2 (interference resistance)
Test voltage:	4.2 KV
Type of construction:	Cable cast in the contact
IP rating:	IP 20 with plug (IP 53 without plug)
Protection grade:	Prepared for protection grade I devices and systems
Ambient temperature:	-20 °C to +60 °C (0 °C to 40 °C without derating)
Relative humidity:	5 to 80 %
Cooling method:	Self-cooling by means of natural convection
Storage temperature:	-25 °C to +85 °C
Input voltage range:	230 V AC input (180 to 264 V input voltage range)
Channel:	50 to 60 Hz
Input current:	Type 0.7 A at 230 V AC
Switch-on current:	< 15 Ap
Mains power failure bridging:	> 20 ms at 230 V AC nominal voltage
Oversvoltage protection:	Yes
Connections:	3 m cable with 3 x 0.75 mm ²
Output voltage:	12 V DC stabilised 2% (SELV)
Output current:	2.0 A 100 % ED/Duty Cycle 3.5 A at 5 % ED/Duty Cycle
Ripple:	<100 m Vpp (at 20 MHz bandwidth)
Control deviation:	Max. 2 %
Current limiting:	Refer to the characteristic line in the diagram
Efficiency:	Type 79 %
Connections:	300 mm x 0.75 mm ²
Dimension:	230 x 25 (29) x 35 mm
Weight:	Approx. 350 g. (including cable)

U/I characteristic line:

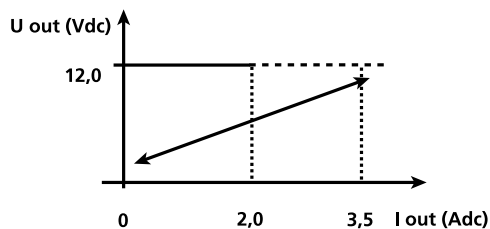

11 Troubleshooting

In the event that your FUHR **autotronic** lock should fail to function properly, please refer to the table below to find and rectify the fault.



IMPORTANT! The entire FUHR **autotronic** lock has been subject to extensive inspections by the manufacturer. If faults are found once installed, the installation should be checked to begin with. The FUHR **autotronic** lock must never be opened forcefully using the lever-handle! All components have been designed for a smooth running operation. The FUHR **autotronic** lock has not been designed to straighten out warped or distorted doors! Careful and proper installation and maintenance of the door is a prerequisite for durable, trouble free operation.

11.1 USE WITH CONTROL UNIT

Type of fault	LED signals of the control unit	Possible cause of fault	Fault repair
The lock does not unlock motor-driven.	Green and red LEDs flash alternately.	Deadbolt doesn't run smoothly.	Check the door installation and possible adjust.
		The door is warped.	Check the door installation and possible adjust.
		The strike plates have been adjusted too tightly.	Readjust/loosen strike plates.
		The central deadbolt has been protracted.	Retract the central deadbolt.
The lock does not unlock.	Green and red LEDs light up.	Data connection between the electronic drive unit and the control unit is interrupted.	Check if the spring-loaded tappet contacts are correctly poled (note +/-; refer to chapter 4.2.2 and chapter 4.2.6).
			Are the spring-loaded tappet contact pins meeting the flat surface contact when the door is closed over?
		One or more cables are damaged.	Check all cables and plug-and-socket connections.
		Tappet contacts and contact surfaces have no contact.	Lubricate the contact surfaces refer to chapter 9.1).
The lock does not lock.		Magnets in the strike plates are out of range.	Readjust the strike plates and/or door. Check the clearance.
	Green LED flashes slowly	The permanently-open function is active.	Switch off the permanently-open function.
The lock does not unlock motor-driven.	No LED lights up.	Power and data connection between the electronic drive unit and the control unit has short-circuited.	Check if the spring-loaded tappet contacts are correctly poled (note +/-; refer to chapter 4.2.2 and chapter 4.2.6).
			Connect the cable to the green multi-functional jack correctly (see chapter 6.3).

Type of fault	LED signals of the control unit	Possible cause of fault	Fault repair
The door cannot be opened by the radio key.	Red LED lights up.	The radio key is not tuned in.	Tune in the radio key.
		The distance to the receiver is too large..	Hold the radio key closer to the door.
		The battery in the radio key is too weak..	Hold the radio key closer to the door and replace the battery.
The door cannot be opened by an external opening impulse..	Red LED lights up.	The external connections are not connected correctly.	Check/establish correct connection to the control unit.
Retracting time is too short for the motorised opening of the latching deadbolts.	Green LED lights up in the closed door leaf setting.	The contact magnet for the motor drive unit is missing.	Install the magnetic contact on the frame and/or insert into the one-piece strike plate.
Door was opened.	Green and red LEDs light up.	This is not a fault. A signal is being transmitted to indicate that the door has been open for more than 20 seconds.	Close the door. The lock will lock automatically.
The latch remain retracted.		The connecting rods are blocked by faceplate screws.	Insert the screws perpendicular to the faceplate.
		External control signal is applied to terminals 9-10 for too long.	Reduce the impulse duration to ≤ 1 second.

11.2 USE WITH RADIO RECEIVER MODULE

The following LED signals can only be checked after connecting the 12 V DC power supply.

LED signal of the programming button	Meaning:
LED is lit continuously	No master key has been paired yet. Note: The first station you pair is the future master station!
LED lights up for 2 sec.	A previously paired transmission signal has been received, the lock is unlocked by motor.
LED lights up for 0.5 sec.	A still unpaired transmission signal was received, the lock does not unlock.
LED does not light at all.	In the non-actuated basic position, the LED does not light up because no transmission signal is received. However, if the LED does not light up despite the transmission of an opening signal, the radio receiver or the motor lock has not yet been connected to the operating voltage of 12 V DC or the cables on the motor plug have been connected incorrectly.

CARL FUHR GmbH & Co. KG

Carl-Fuhr-Straße 12 D-42579 Heiligenhaus
Tel.: +49 2056 592-0 Fax: +49 2056 592-384
www.fuhr.de · info@fuhr.de



All images, dimensions, product and design related information contained in these instructions represent the latest developments regarding the FUHR **autotronic** 834/836 multipoint locking system at the time of printing. This product is subject to FUHR CIP (continuous improvement process) and is constantly enhanced to reflect the latest technology. For the purpose of your satisfaction, we reserve the right to implement changes to this product. Model and product claims cannot be lodged. The latest version of the instructions is published on our website **www.fuhr.de**.